

Standard IoT-Enabled ECOPOWER® Faucet

FEATURES

- Wireless Communication
- Connects seamlessly with Georgia-Pacific's (GP) KOLO™ Smart Monitoring System and through an API to facilities monitoring platforms
- Service agreement with GP required to enable IoT or Smart Features
- ECOPOWER faucet's operation is independent of its IoT capability
- Some of the IoT-enabled Smart Features include: failure detection, usage, water consumption, and battery/capacitor charge
- Self-generating hydropowered ECOPOWER system
- No minimum daily usage requirement
- Micro-sensor positioned underneath the spout head for accurate hand detection ensuring smooth and consistent water distribution
- Vandal resistant aerator housing
- Durable chrome plated spout body
- Single-hole mount
- Kit includes spout body, controller box, and mounting hardware - less supply lines
- Aerated flow
- Contributes to earning LEED® credits
- Equipped with 0.35gpm flow control

MODELS

- TEL103i2-D60E#CP**
 - TELS103 (Standard Spout)
 - TELC103i2-D60E (Controller: 0.35gpm, 60 sec on-demand)
- TEL103i2-D60EM#CP
 - **TEL103i2-D60E#CP** (Standard Spout Kit)
 - TLM10 (Mixing Valve)
- TEL103i2-D60ET#CP
 - **TEL103i2-D60E#CP** (Standard Spout Kit)
 - TLT20 (Thermostatic Mixing Valve)
- TEL103i2-D20E#CP**
 - TELS103 (Standard Spout)
 - TELC103i2-D20E (Controller: 0.11gpc, 20 sec on-demand)
- TEL103i2-D20EM#CP
 - **TEL103i2-D20E#CP** (Standard Spout Kit)
 - TLM10 (Mixing Valve)
- TEL103i2-D20ET#CP
 - **TEL103i2-D20E#CP** (Standard Spout Kit)
 - TLT20 (Thermostatic Mixing Valve)



PRODUCT SPECIFICATION

TOTO Model # _____ The faucet shall have hydropowered self-generating, ECOPOWER System. The faucet shall have maximum of 60 seconds on-demand flow (0.35 gpm) or 20 seconds on-demand flow (0.11gpc). The faucet shall have self-adjusting sensor. Product equipped with 0.35gpm flow regulator.

CODES/STANDARDS

- Operates below federally mandated consumption limit of 0.25gpc
- Complies to California Green Building Code, CALGreen of 0.20 gpc
- Meets or exceeds ASME A112.18.1/CSA B125.1, and NSF 372
- FCC compliant to Part 15
- Certifications: IAPMO(cUPC), State of Massachusetts, and others
- California Green Code and City of Los Angeles Water Efficiency Ordinance
- ADA compliant
- Complies with federal and state statutes as low-lead (contains a weighted average of 0.25% lead or less)
- Complies with CA Prop 65 warning requirements

* For codes and standards of mixing valves TLM10 and TLT20, please refer to corresponding product spec sheet.



TEL103i2 Series

Standard IoT-Enabled ECOPOWER® Faucet

SPECIFICATIONS

Power Supply	ECOPOWER	
Sensor Detection Range	5-1/8" - 7-7/8" (130 - 200mm) Sensor is self-adjusting	
Water Supply Pressure	Min (Dynamic/Flowing) Pressure: 15 psi (100kPa) Max (Static) Pressure: 80 psi (551kPa)	
Water Supply	G1/2 (1/2 NPSM compatible)	
Inlet Temperature Range	39-110°F(4-42°C)	
Ambient Temperature	32-104°F(0-40°C)	
Humidity	Max. 90% RH	
Flow Rate	D20E	0.11 gpc* - max 20 second On-Demand** (0.11 gpc = 0.35 gpm x 20/60 sec) Equipped with 0.35 gpm flow control
	D60E	0.35 gpm
Warranty	Three years	

*Gallons per cycle (gpc) is the amount of water per usage cycle .

**On-demand refers to the way in which the water is dispersed (i.e.; water is only dispersed when the sensor is activated by the user as needed).

NOTE

Following the federal mandate for water efficiency outlined in the Environmental Protection Act of 1992, faucets can be rated for water consumption based on two categories: Flow Rate and Water Consumption. TOTO uses the water consumption standard because it is the most accurate method of measuring water use. TOTO faucets also comply with the CALGreen Guideline of water usage.

Water Saving

On-Demand [20 sec.] faucet (0.11gpc)
Federal Standard (0.25gpc) -56% less
CAL Green (0.20gpc) -45% less

Standard

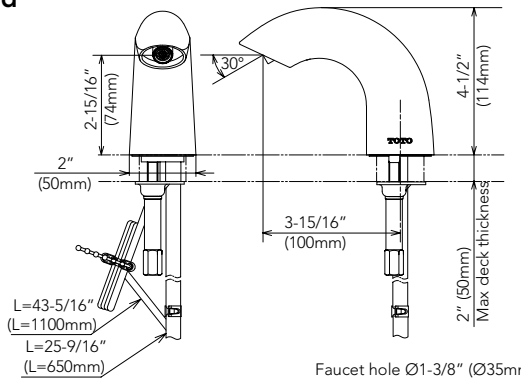

Controller

The IoT daughter card installation requires minimum 13/16" (20mm) clearance on the left side of the controller. Please refer to the diagram, as shown.

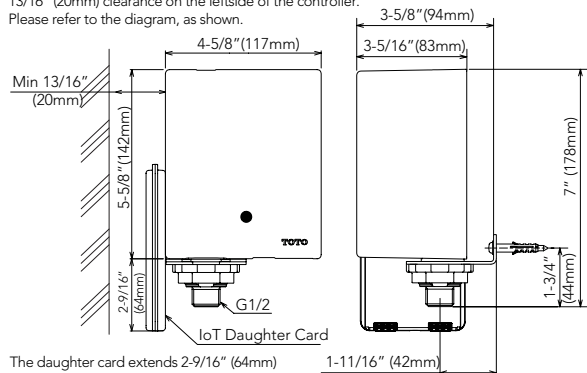

Available Mixing Valves

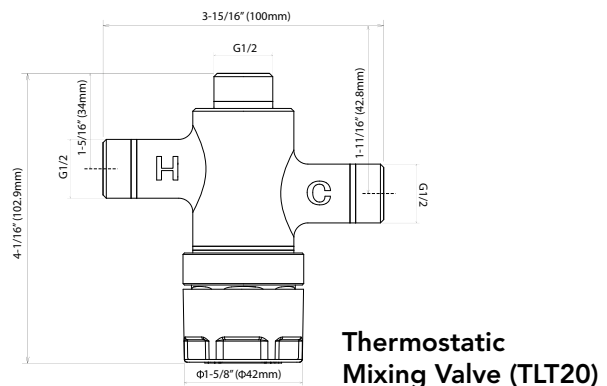
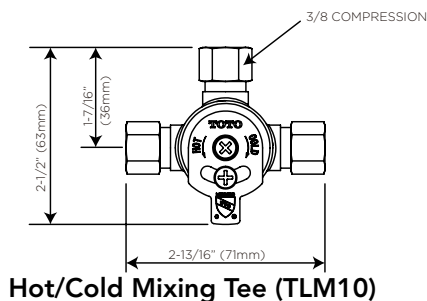

TOTO®

These dimensions and specifications are subject to change without notice