

Libella™ Wall-Mount EcoPower® Faucet

FEATURES

- Self-generating hydropowered EcoPower system
- No minimum daily usage requirement
- Micro-sensor positioned underneath the spout head for accurate hand detection ensuring smooth and consistent water distribution
- Vandal resistant aerator housing
- Durable chrome plated spout body
- Wall mount
- Kit includes spout body, controller box, and mounting hardware - less supply lines
- Equipped with 1.0gpm flow control

MODELS

- TEL1C1-D10E**
 - TELS1C1 (Libella Wall-Mount Spout)
 - TELC101R-D10E (Controller: 0.18gpc, 10 sec on-demand)
- TEL1C1-D10EM
 - **TEL1C1-D10E** (Libella Wall-Mount Spout Kit)
 - TLM10 (Mixing Valve)
- TEL1C1-D10ET
 - **TEL1C1-D10E** (Libella Wall-Mount Spout Kit)
 - TLE05701U (Thermostatic Mixing Valve)

COLORS/FINISHES

- #CP Polished Chrome

OPTIONAL ACCESSORIES

- THP3237 - Swivel Coupling

PRODUCT SPECIFICATION

TOTO Model # _____ Product shall have hydropowered self-generating, EcoPower System. Product shall have vandal resistant aerator. Product shall have maximum of 10 seconds on-demand flow (0.18gpc). Product shall have anti-scald shape memory alloy thermostatic mixing valve (-ET models only). Product shall have self-adjusting sensor.



CODES/STANDARDS

- Operates below federally mandated consumption limit of 0.25gpc.
- Complies to California Green Building Code/ CALGreen of 0.20gpc.
- Complies with Federal and State statutes as low-lead (contains a weighted average of 0.25% lead or less).
- Complies with City of Los Angeles Water Efficiency Ordinance.
- Certifications: IAPMO(cUPC), California Energy Commission (CEC) State of Massachusetts, and others.
- Meets or exceeds ASME A112.18.1M/CSA B125.1, and NSF372-2011.
- ADA compliant.

* For codes and standards of mixing valves TLM10 and TLE05701U, please refer to corresponding product spec sheets.



TEL1C1 Series

Libella™ Wall-Mount EcoPower® Faucet

SPECIFICATIONS

Power Supply	EcoPower
Sensor Detection Range	5-1/8" - 7-7/8" (130 - 200mm) Sensor is self-adjusting
Water Supply Pressure	Min (Flowing) Pressure: 15psi (100 kPa) Max (Static) Pressure: 80 psi (551kPa)
Water Supply	G1/2 (1/2 NPSM compatible)
Inlet Temperature Range	39-110°F(4-42°C)
Ambient Temperature	32-104°F(0-40°C)
Humidity	Max. 90% RH
Flow Rate	0.18 gpc* - max 10 second On-Demand** (0.18 gpc = 1.0 gpm x 10/60 seconds) Equipped with 1.0 gpm flow control
Warranty	Three year limited

*Gallons per cycle (gpc) is the amount of water per usage cycle .

** On-demand refers to the way in which the water is dispersed (i.e.; water is only dispersed when the sensor is activated by the user as needed).

NOTE

Following the federal mandate for water efficiency outlined in the Environmental Protection Act of 1992, faucets can be rated for water consumption based on two categories: Flow Rate and Water Consumption. TOTO uses the water consumption standard because it is the most accurate method of measuring water use. TOTO faucets also comply with the CALGreen Guideline of water usage.

Water Saving

On-Demand [10 sec.] faucet (0.18gpc)
30% less than Federal Standard (0.25gpc)
10% less than CAL Green (0.20gpc)

Libella Wall-Mount

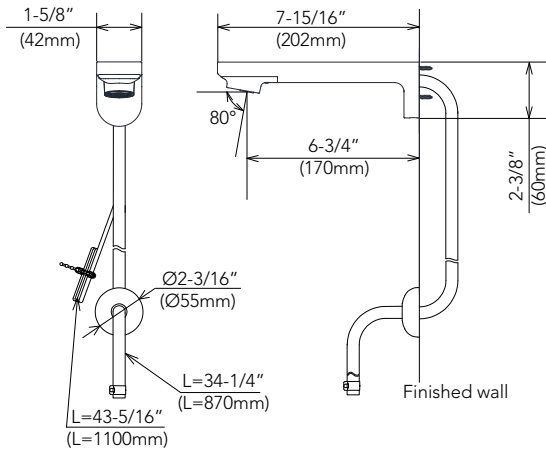

Controller

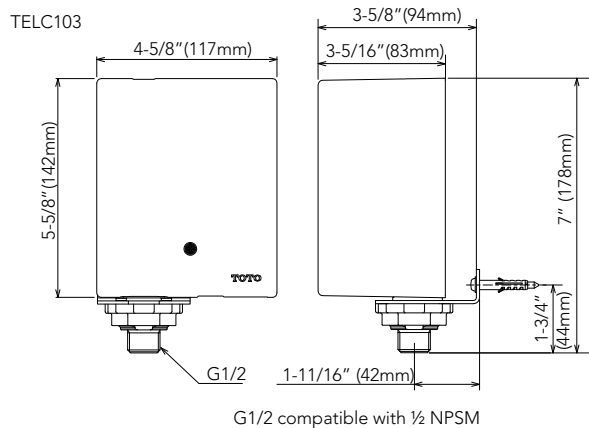

Available Mixing Valves

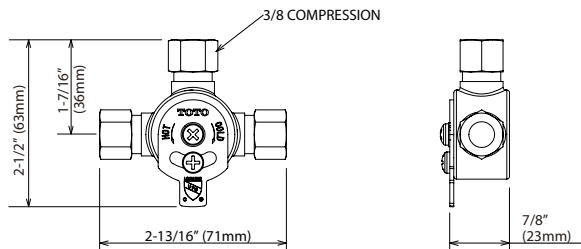

Hot/Cold Mixing Tee (TLM10)

Thermostatic Mixing Valve (TLE05701U)

TOTO

These dimensions and specifications are subject to change without notice