

Helix® M EcoPower® Faucet

FEATURES

- Self-generating hydropowered EcoPower system
- No minimum daily usage requirement
- Micro-sensor positioned underneath the spout head for accurate hand detection ensuring smooth and consistent water distribution
- Vandal resistant aerator housing
- Durable chrome plated spout body
- Single-hole mount
- Kit includes spout body, controller box , and mounting hardware - less supply lines
- 0.5 gpm aerated flow

MODELS

- TEL125-D10E**
 - TELS125 (Helix M Spout)
 - TELC105R-D10E (Controller: 0.09gpc, 10 sec on-demand)
- TEL125-D10EM
 - **TEL125-D10E**
 - TLM10 (Mixing Valve)
- TEL125-D10ET
 - **TEL125-D10E**
 - TLE05701U (Thermostatic Mixing Valve)
- TEL125-C20E**
 - TELS125 (Helix M Spout)
 - TELC105R-C20E (Controller: 0.19gpc, 20 sec continuous)
- TEL125-C20EM
 - **TEL125-C20E**
 - TM10 (Mixing Valve)
- TEL125-C20ET
 - **TEL125-C20E**
 - TLE05701U (Thermostatic Mixing Valve)

COLORS/FINISHES

- #CP Polished Chrome

OPTIONAL ACCESSORIES

- THP3158#CP - 4" Cover Plate
- THP3159#CP - 8" Cover Plate
- TH559EDV566 – Laminar Flow Nozzle
- THP3237 - Swivel Coupling



PRODUCT SPECIFICATION

TOTO Model # _____ The faucet shall have hydropowered self-generating, EcoPower System. The faucet shall have maximum of 10 seconds on-demand flow (0.09gpc), or 20 seconds continuous flow (0.19gpc). Product shall have anti-scald shape memory alloy thermostatic mixing valve (-ET models only). The faucet shall have self-adjusting sensor.

CODES/STANDARDS

- Operates below federally mandated consumption limit of 0.25gpc
- Complies to California Green Building Code, CALGreen of 0.20 gpc
- Meets or exceeds ASME A112.18.1M/CSA B125.1, and NSF372-2011
- Certifications: IAPMO(cUPC), State of Massachusetts, and others
- California Green Code and City of Los Angeles Water Efficiency Ordinance
- ADA compliant
- Complies with federal and state statutes as low-lead (contains a weighted average of 0.25% lead or less)

* For codes and standards of mixing valves TLM10 and TLE05701U, please refer to corresponding product spec sheets.



TEL125 Series

Helix® M EcoPower® Faucet

SPECIFICATIONS

Power Supply	EcoPower
Sensor Detection Range	5-1/8" - 7-7/8" (130 - 200mm) Sensor is self-adjusting
Water Supply Pressure	Min (Dynamic/Flowing) Pressure: 15psi (100kPa) Max (Static) Pressure: 80 psi (551kPa)
Water Supply	G1/2 (1/2 NPSM compatible)
Inlet Temperature Range	32-110°F(0-42°C)
Ambient Temperature	32-104°F(0-40°C)
Humidity	Max. 90% RH
Flow Rate	0.09 gpc* - max 10 second On-Demand** (0.09 gpc = 0.5 gpm x 10/60 sec) Equipped with 0.5 gpm flow control
	0.19 gpc* - 20 second Continuous*** (0.19 gpc = 0.5 gpm x 20/60 sec) Equipped with 0.5 gpm aerated flow
Warranty	Three years

NOTE

Following the federal mandate for water efficiency outlined in the Environmental Protection Act of 1992, faucets can be rated for water consumption based on two categories: Flow Rate and Water Consumption. TOTO uses the water consumption standard because it is the most accurate method of measuring water use. TOTO faucets also comply with the CALGreen Guideline of water usage.

Water Saving

On-Demand [10 sec.] faucet (0.09gpc)
Federal Standard (0.25gpc) – 64% less
CAL Green (0.20gpc) – 55% less

Continuous [20 sec.] faucet (0.19gpc)
Federal Standard (0.25gpc) – 24% less
CAL Green (0.20gpc) – 5% less

*Gallons per cycle (gpc) is the amount of water per usage cycle .

** On-demand refers to the way in which the water is dispersed (i.e.; water is only dispersed when the sensor is activated by the user as needed).

*** Continuous means that water is dispersed for a continuous 20 second cycle.

Helix M

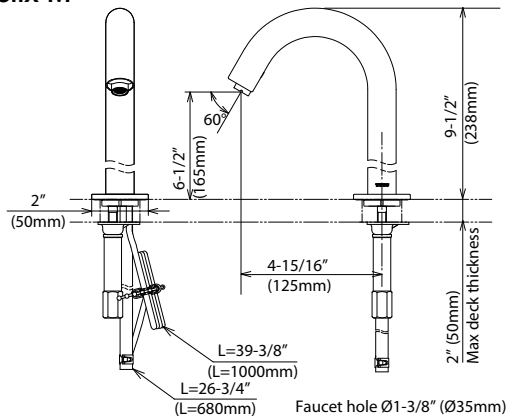

Available Mixing Valves

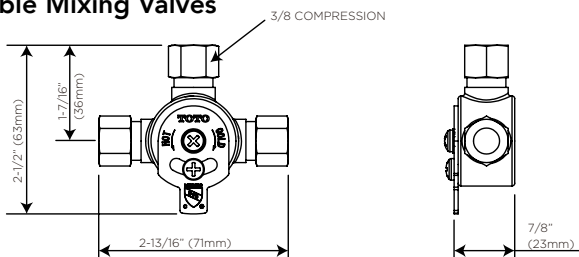

Hot/Cold Mixing Tee (TLM10)

Controller

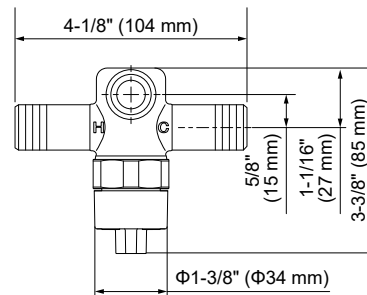
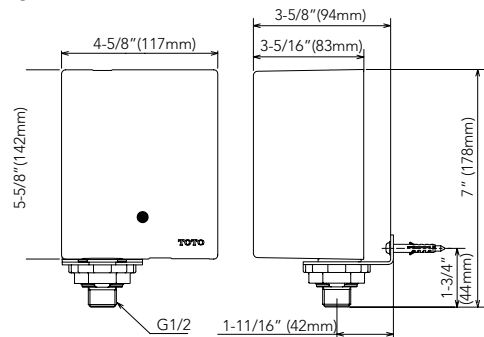

Thermostatic Mixing Valve (TLE05701U)

TOTO

These dimensions and specifications are subject to change without notice