

ECOPOWER Exposed Flush Valve IoT Communication Card Installation Manual

TET1UBi*#CP/TET1LBi*#CP/TET1GBi*#CP/TET6UBi*#CP/TET6LBi*#CP/TET6GBi*#CP/TEU1UAI*#CP/TEU1LAI*#CP/TEU1GAI*#CP

* indicates '2' for TOTO/Georgia-Pacific IoT system, '4' for TOTO/TeraCode IoT system

NOTE: Install the flush valve according to the Flush Valve Installation Manual.

INCLUDED PARTS

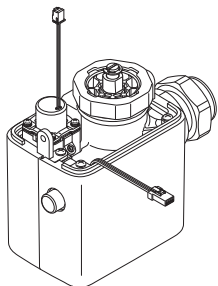

Valve Body Assembly*
(* may vary in appearance depending on model. TET1UBi*#CP model shown.)

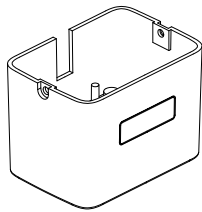

Top Cover



Backup Battery

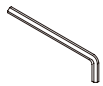

Hex Wrench and Screws



Flush Valve Installation Manual

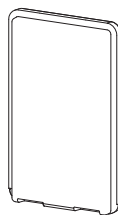

IoT Communication Card

THP3395 (for i2 system)
THP3566 (for i4 system)

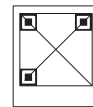

QR Code Sticker



AA Batteries x4
(for i4 system)

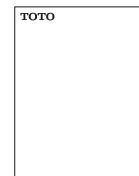

IoT Communication Card Installation Manual
(Refers to this document)

WARNINGS

Please read and adhere to these notes. Failure to do so could result in personal injury, risk of fire or smoke and/or property damage.

- Install the product according to installation instructions.
- Install the product in the correct vertical orientation.
- Do not use or operate the product with it's covers removed.

BEFORE INSTALLATION

Make sure there is enough space for the IoT communication card to attach on the flush valve without interference. A minimum of 13/16" (20mm) clearance between the back of the flush valve and the wall is required.

Do not drop the IoT communication card! Handle with care!

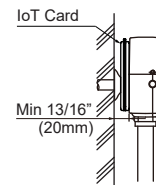

INSTALLATION PROCEDURE

For i2 system

1. Pull the battery tab out from IoT communication card.

NOTE: Red LED light will blink to indicate that the IoT communication card is functioning.

For i4 system

1. Remove the battery cover, and install the 4 AA batteries included in the package.

NOTE: Green LED light will blink to indicate that the IoT communication card is functioning.

2. Remove the flush valve top cover.
3. Apply the QR code sticker onto the inner surface of the flush valve top cover.
4. Connect the IoT wire harness (black and white). Listen for the "click" indicating a secure connection.
5. Commit the IoT communication card according to TOTO's Instructions.
6. Slide the hook of the IoT communication card up into the notch of the top cover.
7. Hold the IoT communication card and top cover together and carefully guide into place onto the valve body.
8. Secure the top cover to the valve body.

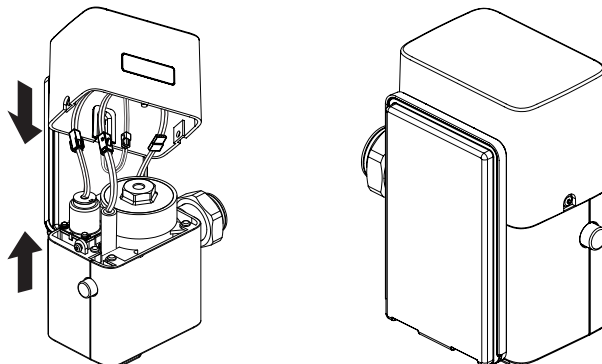
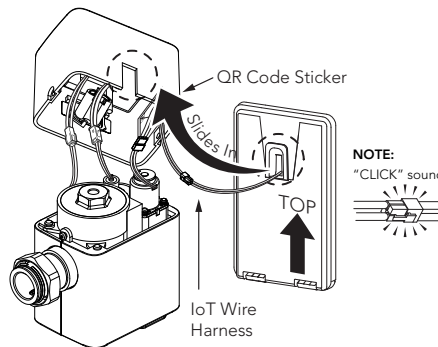
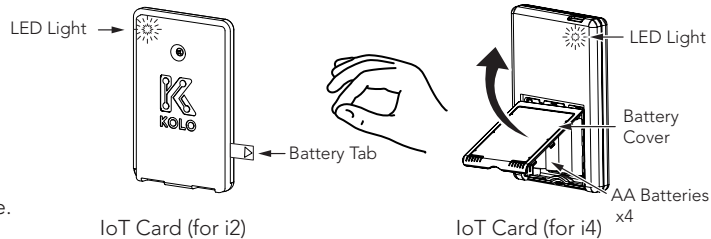

For any questions regarding installation or maintenance, please contact:
TOTO at (888) 295-8134
(For i2 system) Georgia-Pacific at (800) 890-0896 or KOLOhelp@gapac.com
(For i4 system) TeraCode at (800) 305-2310 or totosupport@teracode.com

TET1UBi*#CP/TET1LBi*#CP/TET1GBi*#CP/TET6UBi*#CP/TET6LBi*#CP/TET6GBi*#CP/TEU1UAI*#CP/TEU1LAI*#CP/TEU1GAI*#CP

* indicates '2' for TOTO/Georgia-Pacific IoT system, '4' for TOTO/TeraCode IoT system

MAINTENANCE WARNINGS

Follow these instructions carefully. Failure to do so could result in personal injury, risk of fire, smoke and/or property damage.

- Handle the product with care when performing maintenance.
- DO NOT pull, twist or damage the wires or connectors. Risk of product malfunction.
- NEVER splash water on the components. This is an electrical device. DO NOT get the components wet. Risk of product malfunction.

Follow these instructions carefully. Failure to do so could cause incorrect data reporting.

- Each IoT communication card has been electronically paired to a specific valve. DO NOT MIX UNPAIRED SIMILAR COMPONENTS EVEN WHEN VISUALLY IDENTICAL.
- When providing maintenance, please keep track of paired components.
- Make sure paired IoT communication card reconnects to its exact corresponding paired valve.
- Failure to reconnect corresponding paired components will result in product malfunction.

MAINTENANCE INSTRUCTIONS

Replacing the batteries:

1. Loosen and remove the two (2) side screws of the flush valve top cover.
- NOTE:** The IoT communication card is not secured to the top cover and only tethered by a connection wire. Cradle both parts together, otherwise the IoT communication card may slip down, fall, and break.
2. Using both hands, carefully lift the top cover and IoT communication card from the valve body.
 3. Locate the connector for the IoT communication card and disengage.
 4. Carefully place the top cover back onto the valve body, making sure not to pinch or kink the wire connections.
 5. (For i2 system) Open the IoT communication card by loosening captive screw to access the batteries.
(For i4 system) Remove the battery cover to access the batteries.
 6. Remove the four (4) AA batteries and replace with four (4) new AA alkaline batteries.
 7. (For i2 system) Carefully close the IoT communication card. Tighten captive screw. Do not overtighten.
(For i4 system) Install the battery cover back to securely lock the batteries in position.
 8. Reattach as per installation instructions on reverse.

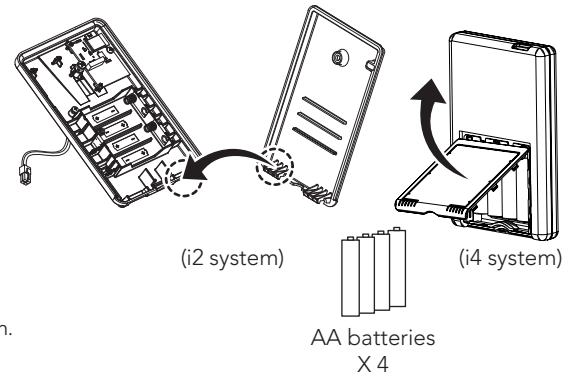

REGULATORY STATEMENTS

FCC:

This device complies with Part 15 of the FCC Rules. Operation is subject to the following two conditions:

1. This device may not cause harmful interference, and
2. This device must accept any interference received, including interference that may cause undesired operation.

Changes or modifications not expressly approved by the party responsible for compliance could void the user's authority to operate the equipment.

FCC Interference Statement Part 15.105 (b)

This equipment has been tested and found to comply with the limits for a Class B digital device, pursuant to Part 15 of the FCC Rules. These limits are designed to provide reasonable protection against harmful interference in a residential installation. This equipment generates uses and can radiate radio frequency energy and, if not installed and used in accordance with the instructions, may cause harmful interference to radio communications. However, there is no guarantee that interference will not occur in a particular installation. If this equipment does cause harmful interference to radio or television reception, which can be determined by turning the equipment off and on, the user is encouraged to try to correct the interference by one of the following measures:

- Reorient or relocate the receiving antenna.
- Increase the separation between the equipment and receiver.
- Connect the equipment into an outlet on a circuit different from that to which the receiver is connected.
- Consult the dealer or an experienced radio/TV technician for help.

To comply with FCC and Industry Canada RF exposure limits for general population / uncontrolled exposure, the antenna(s) used for this transmitter must be installed to provide a separation distance of at least 43mm from all persons and must not be operating in conjunction with any other antenna or transmitter, except in accordance with FCC multi-transmitter product procedures.

Industry Canada:

This Device complies with Industry Canada License-exempt RSS standard(s). Operation is subject to the following two conditions: 1) this device may not cause interference, and 2) this device must accept any interference, including interference that may cause undesired operation of the device.

Cet appareil est conforme avec Industrie Canada, exempts de licence standard RSS (s). Son fonctionnement est soumis aux deux conditions suivantes: 1) ce dispositif ne peut pas causer d'interferences. et 2) ce dispositif doit accepter toute interference, y compris les interferences qui peuvent causer un mauvais fonctionnement de l'appareil.

Under Industry Canada regulations, this radio transmitter may only operate using an antenna of a type and maximum (or lesser) gain approved for the transmitter by Industry Canada. To reduce potential radio interference to other users, the antenna type and its gain should be so chosen that the equivalent isotropically radiated power (e.i.r.p.) is not more than that necessary for successful communication.